



**ROTATING MACHINERY TECHNOLOGY, INC.**  
PRECISION BEARINGS AND SEALS  
TURBOMACHINERY REPAIR AND SERVICE  
ROTOR DYNAMIC ANALYSIS

# **OPERATING TURBOMACHINERY ON OR NEAR THE SECOND CRITICAL SPEED IN ACCORDANCE WITH API SPECIFICATIONS**

**JOHN C. NICHOLAS, Ph.D.**  
*Rotating Machinery Technology, Inc.*

**JULY 2000**

# OPERATING TURBOMACHINERY ON OR NEAR THE SECOND CRITICAL SPEED IN ACCORDANCE WITH API SPECIFICATIONS

by

John C. Nicholas

President

Rotor Bearing Dynamics, Incorporated

Wellsville, New York



*John C. Nicholas received his B.S.A.E. degree from the University of Pittsburgh (1968), his M.S.M.E. degree from Northwestern University (1969), and his Ph.D. degree (1977) from the University of Virginia in rotor bearing dynamics. While at Virginia, he authored the tilting pad and pressure dam bearing computer programs that are used by many rotating equipment vendors and users.*

*Dr. Nicholas has worked in the rotating equipment industry for the last eleven years in the rotordynamics area, including five years at Ingersoll-Rand and five years as the supervisor of the rotordynamics group at the Steam Turbine, Motor, and Generator Division of Dresser-Rand.*

*Currently, Dr. Nicholas operates a vibration consulting company, Rotor Bearing Dynamics, Incorporated. He is also a part owner and chief design engineer for Rotating Machinery Technology, Incorporated, a company that manufactures high performance bearings and seals.*

*Dr. Nicholas, a member of ASME, STLE, and the Vibration Institute, has authored more than 24 technical papers in rotor bearing dynamics. He has also been an associate editor for STLE's Tribology Transactions for the past three years.*

## ABSTRACT

The question of when is it safe to operate turbomachinery on or near the second critical speed is addressed. A parallel evolutionary progression of the API rotordynamic specifications and rotordynamic analysis capabilities is discussed. Actual test stand results are presented, illustrating second critical speeds near the operating range with high amplification factors and low amplification factors. Their rotordynamic characteristics are discussed in reference to the old and new API specifications and the older and more recent rotordynamic analyses. One example is shown of a steam turbine that operates with the second critical inside the API separation margin. Actual speed-amplitude plots are presented for the unbalance sensitivity testing of the steam turbine on the test stand in accordance with the second edition and the latest third edition of API 612 steam turbine specifications. The results show that the turbine fails the second edition test by a factor of two but passes the third edition test by a factor of four. Finally, the implications of these results are discussed in reference to safe operation of rotating equipment on or near the second critical speed in accordance with the newest edition of API specifications.

## INTRODUCTION

Many of the turbomachines operating today run on or very near the second critical speed. Some run without any apparent vibration problems. Others are labeled problem machines, re-

quiring constant attention to keep the vibration below the trip level. Some machines are purposely designed to operate near the second critical speed because of the need for higher performance requirements and thus higher speeds. Others are designed to run below the second critical speed but end up running directly on the second.

This problem was recognized by Tuttle [1] in the late sixties. He states that many

... 'flexible shaft' distributed-mass rotors... have certainly been running above the second critical for years. The oil film stiffness that manufacturers have had to assume to justify the conclusion that earlier successful machines were operating below the second critical has always been unreasonably high.

He goes on to say that methods

... existed to calculate the second critical but... were rarely, if ever, used. It was generally assumed that the second critical was at least three times the first and, therefore, of little concern.

Major advances have been made in the last twenty years in analytical rotor and bearing dynamics that have led to improved critical speed predictions. In the fifties, prior to the general availability of fluid film bearing dynamic analysis codes, the rotor criticals were predicted based on rigid bearing analyses. With the development of the high speed computer, dynamic bearing programs became available in the late sixties and seventies. The landmark paper by Lund [2] concerning the pad assembly method for tilting pad bearings certainly contributed greatly to this advance in bearing technology.

With flexible bearing properties, critical speed predictions improved greatly. However, as stated by Tuttle [1], second critical speed predictions continued to remain on the high side due to unreasonably high oil film stiffnesses. This problem has been addressed in the eighties by including the support or pedestal flexibility [3, 4, 5, 6] in rotordynamic analyses. With both bearing and pedestal flexibility included, accurate second critical speed prediction is attainable [4, 5]. These advances have resulted in much lower, more accurate and more realistic critical speed predictions, leading to the realization that many high speed rotating machines operate on or near the second critical speed.

During the same time period, rotordynamic specifications were written and adopted by the American Petroleum Institute (API). The steam turbine specification, 612, has gone through three revisions since its inception in 1969 [7, 8, 9]. The first edition [7] prohibits operation on or near any critical speed regardless of its sensitivity. Tuttle [1] comments on this prohibition by stating that the "idea of specifying a maximum amplification factor is suggested as an alternative to an absolute prohibition against critical speeds in the operating speed range."

In 1979, a second edition to API 612 [8] established a separation margin. This separation margin placed critical speeds at least 20 percent above maximum speed and 15 percent below minimum speed. However, if a critical speed violated the separation margin, it might still be acceptable if the rotor passed an unbalance sensitivity test.

The third and most current edition [9] establishes a separation margin that is a function of the rotor's sensitivity or amplification factor. Furthermore, if the amplification factor is less than 2.5, the critical is considered critically damped and no separation margin is required.

Much of this study addresses the implications of critically damped criticals and the acceptability of operating on or near a critical whose amplification factor is less than 2.5. To this end, analytical and/or test stand results are presented for three different steam turbines. These results illustrate the necessity of using flexible supports for accurate second critical speed predictions. Furthermore, the test stand results show example unbalance tests for the 2nd and 3rd editions of API 612. Two turbines have critically damped second criticals while the third turbine has a second critical with a high amplification factor. The study concludes that with proper analytical procedures (i.e., inclusion of support flexibility) turbomachinery may be designed to operate safely with an overdamped second critical within the operating speed range in accordance with the latest edition of API rotordynamic specifications.

#### Rotordynamic Analyses

In order to illustrate the development of analytical rotordynamic techniques, a typical ethylene plant process gas drive turbine is used as an example. Some of the important rotor characteristics are listed in Table 1. Note that the rotor weight is 16,462 lb and the maximum operating speed is 5043 rpm.

A rigid bearing, rigid pedestal model is illustrated in Figure 1. The results of this undamped critical speed analysis are shown in Figure 2. The critical speed map shows that the rigid bearing second critical is located at 9555 rpm.

Table 1. Rotor Characteristics, Process Gas Drive Turbine.

Rotor Weight (lb)	16462
Bearing Span (in)	157.4
Midshaft Diameter (in)	18.0
Journal Diameters (in)	10.0/8.0*
MCOS (rpm)	5043
Overhang Lengths (in)	16.0/26.3*
Bearings	4 tilting pad
$N_1/A_1$ (predicted)**	2200/7.3
$N_2/A_2$ (predicted)**	5500/2.3
$N_1/A_1$ (actual)***	2300/7.7
$N_2/A_2$ (actual)***	5400/3.2

\*Exhaust/Steam End

\*\*With  $KS = 5.0E6$  lb/in

\*\*\*Estimated from Figure 13, Exhaust End

A model including flexible bearings is shown in Figure 3. Including the bearing stiffness and damping properties as a function of speed, along with the mass-elastic model of the rotor, results in the response plot shown in Figure 4. With flexible bearings, the second critical is now predicted at 7100 rpm.

Inclusion of the pedestal flexibility along with the bearing flexibility results in a model shown in Figure 5. The dynamic support properties may be obtained with an impact hammer rap test on each bearing housing [5], as illustrated in Figure 6. Results of the rap test for the process gas turbine are shown in Figure 7 for the steam end vertical direction. At the approximate location of the second critical (6000 cpm), the dynamic stiffness is  $5.0E6$  lbs/in. Inclusion of this support stiffness in the response analysis results in the response plot shown in Figure 8. Now, the second critical speed is predicted at 5500 rpm with an amplification fac-

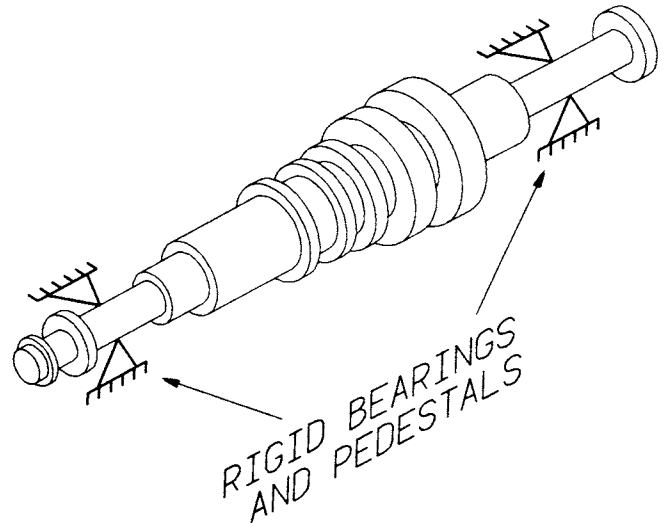

Figure 1. Rigid Bearing, Rigid Pedestal Model.

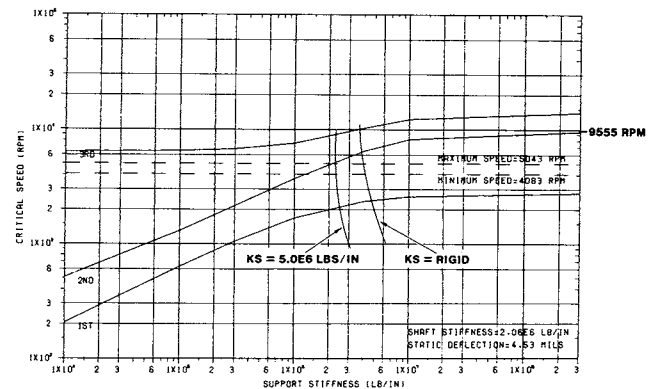

Figure 2. Critical Speed Map, Process Gas Drive Turbine.

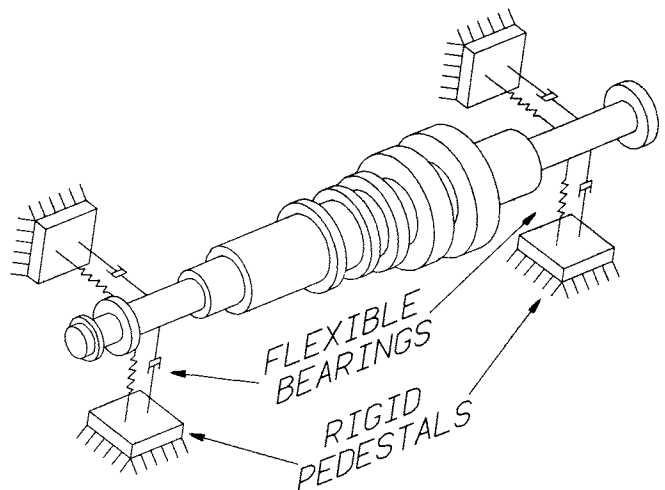

Figure 3. Flexible Bearing, Rigid Pedestal Model.

tor of 2.3. The corresponding rotor mode shape is shown in Figure 9.

These results are summarized in Table 2. Note that the estimated actual second critical is at 5400 rpm. Clearly, without inclusion of the support flexibility, the second critical is predicted

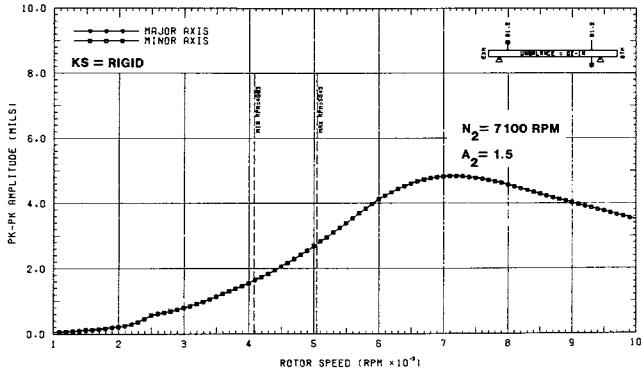

Figure 4. Response Plot, Process Gas Drive Turbine, Rigid Pedestals.

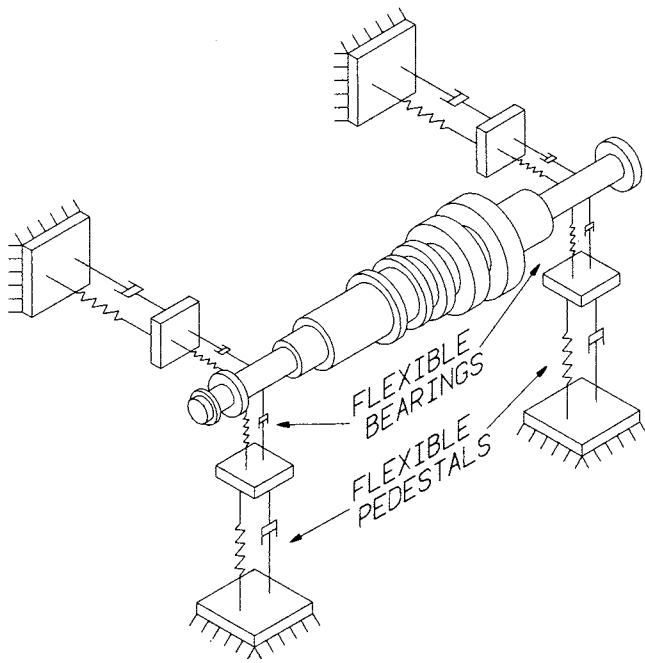

Figure 5. Flexible Bearing, Flexible Pedestal Model.

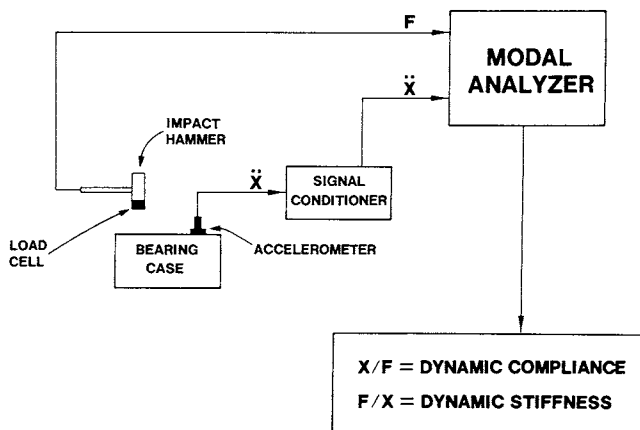

Figure 6. Instrumentation Schematic for Determination of Support Stiffness.

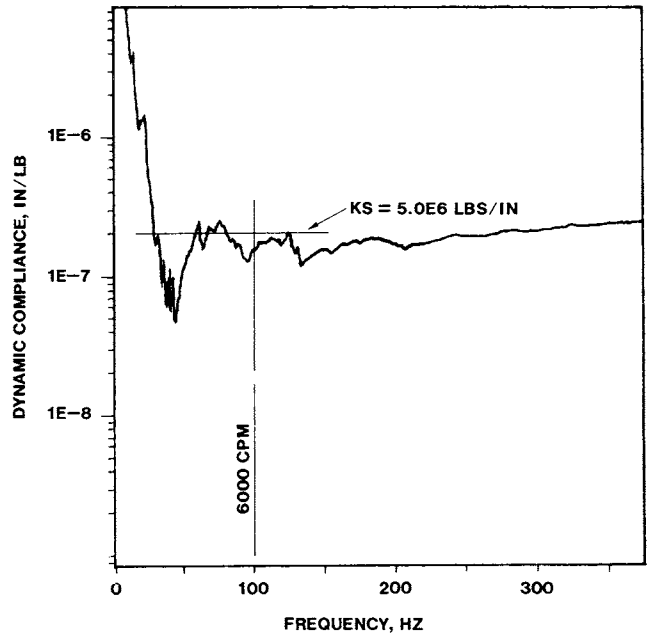

Figure 7. Dynamic Compliance, Process Gas Drive Turbine, Steam End Vertical.

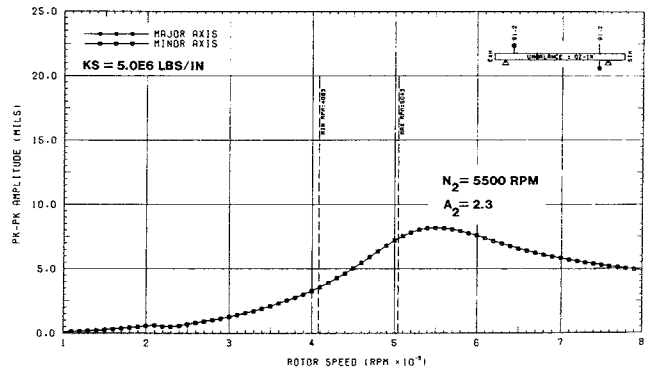

Figure 8. Response Plot, Process Gas Drive Turbine, Flexible Pedestal Model.

to be well above operating speed, whereas its true location is essentially right on the turbine's maximum continuous speed.

Returning to Figure 2, the total (bearing plus pedestal) support stiffness lines are also included on the critical speed map. This quite clearly illustrates the reduction in the prediction of the location of the second critical from the rigid bearing prediction to the flexible bearing, rigid pedestal prediction ( $KS = \text{rigid}$ ) to the flexible bearing, flexible pedestal prediction ( $KS = 5.0E6 \text{ lbs/in}$ ).

From these results, it is easy to see how many machines designed in the sixties to operate below the second critical speed actually ended up operating on the second critical. Without the analytical tools necessary to include even the bearing flexibility, realistic critical speed predictions were not possible.

#### API Specifications

Since all of the examples presented in this paper are steam turbines, discussion of the API specifications will be limited to the steam turbine specifications, API 612. However, the rotor-

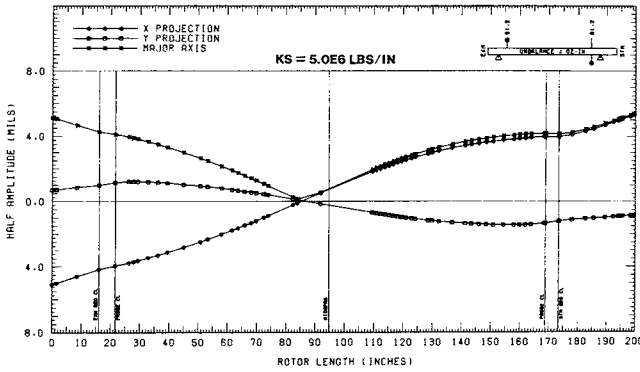

Figure 9. Mode Shape Plot at 5043 RPM, Process Gas Drive Turbine, Flexible Pedestal Model.

Table 2. Comparison of Predicted Second Critical Speeds and Amplification Factors, Process Gas Drive Turbine.

Model	$N_2$ (rpm)	$A_2$
Rigid Bearing, Rigid Pedestal Figure 2	9555	--
Flexible Bearing, Rigid Pedestal Figure 4	7100	1.5
Flexible Bearing, Flexible Pedestal KS = 5.0E6 lb/in, Figure 8	5500	2.3
Actual, Figure 13	5400*	3.2*

\*Estimated values

dynamic sections are essentially identical for the compressor specifications, API 617. Therefore, this section is also applicable to API 617.

The rotordynamic sections that apply to critical speed location from API 612, first edition are summarized in Table 3. Note that all criticals, regardless of sensitivity or amplification factor are excluded from the operating speed range.

Table 3. API 612 1st Edition Summary.

- $N_1$  over 10 percent of trip speed.
- Or  $N_1$  less than 60 percent of MCOS and 10 percent away from any operating speed.
- $N_2$  at least 10 percent above trip speed.

The second edition of API 612 was adopted in 1979 [8]. This edition establishes a separation margin that places critical speeds at least 20 percent above maximum speed and 15 percent below minimum speed (Table 4). However, if a critical speed violates the separation margin, it may still be acceptable if the rotor passes an unbalance sensitivity test. While this allowed some design flexibility, the unbalance test is expensive, time consuming and after the fact [10].

Some of the philosophy in writing and adopting the third edition to API 612 (fifth edition of API 617) was revealed by Raynesford [10]. He states that the main cause for concern is threefold: pounding out the bearings, destructive rubs and imposing unrealistic restrictions on the designer. Some of the third edition specifications that relate to critical speed location are listed in Table 5. By far, the most innovative section concerns critical

Table 4. API 612 2nd Edition Summary.

- Amplification factors must be below 8.0.
- Separation Margin—20 percent above MCOS  
15 percent below minimum
- If  $N_1$  or  $N_2$  within separation margin, unbalance sensitivity test

- Amount of unbalance, UB = 5 times API residual unbalance

$$UB = 5 \left[ \frac{56,347 \text{ WT}}{N^2} \right] \text{ oz-in}$$

- Vibration must be below twice API vibration limit

$$V = 2 \sqrt{\frac{12000}{N}}$$

where  $N = \text{MCOS}$

speeds whose amplification factors are below 2.5. These criticals are considered critically damped and no separation margin is required [9].

Clearly, the acceptability of critically damped criticals in the operating speed range offers much more design flexibility than the second edition of API 612. It is not a coincidence that this flexibility was offered by API after the rotordynamic analytical tools were developed for accurate critical speed prediction. From the previous section, this cannot be accomplished without inclusion of the pedestal flexibility. These points are addressed by Raynesford [10] with his statement that the users should “believe that we have developed the technology to the point that we can accurately predict mechanical performance.”

Another important change in the third edition of API 612 is that a shop verification unbalance test is required for all rotors. The importance of this requirement is illustrated in the next section.

#### Applying API 612 Second Edition

As an example of applying the second edition of API 612, consider the light (620 lb), high speed (MCOS = 10,920 rpm) rotor whose characteristics are summarized in Table 6. Note that the second critical is predicted at 12,000 rpm with an amplification factor of 2.3. This prediction is based on a flexible bearing, flex-

Table 5. API 612 3rd Edition Summary.

- Separation Margin
  - None required if  $A$  less than 2.5  
(Response is considered critically damped)
  - $A = 2.5$  to 3.55—15 percent above MCOS  
5 percent below minimum
- $A$  greater than 3.55—Up to 26 percent above MCOS  
—Up to 16 percent below minimum
- Shop verification test required regardless of separation margin for each critical in question

- Amount of unbalance = 2 to 8 times  $4W/N$

$$W = \text{Journal Static Load}$$

$$N = \text{MCOS}$$

Adjust amount to raise vibration at probes (at min. or MCOS) to vibration limit of

$$V = \sqrt{\frac{12000}{N}}$$

where  $N = \text{MCOS}$  or min. speed

- Vibration must be below 75 percent of minimum seal clearances throughout machine from zero to trip speed

ible pedestal model (Figure 5) with  $KS = 3.0E6$  lb/in. Thus, in accordance with the second edition, an unbalance test is required since the second critical is within the separation margin.

Table 6. Rotor Characteristics, High Speed Turbine.

Rotor Weight (lb)	620
Bearing Span (in)	49.6
Midshaft Diameter (in)	6.0
Journal Diameters (in)	3.5/3.0
MCOS (rpm)	10920
$N_1/A_1$ (predicted)*	5600/2.5
$N_2/A_2$ (predicted)*	12000/2.3
$N_2/A_2$ (actual)**	12000/2.6

\*With  $KS = 3.0E6$  lb/in

\*\*Estimated from Figure 10

The results of this test are illustrated in Figure 10. In the balanced condition, evidence of the second critical is almost nonexistent. The speed-amplitude plot for the unbalance test clearly shows the second critical to be located at approximately 12000 rpm with an amplification factor of 2.6. The vibration limit from Table 4 is 2.1 mils peak-to-peak. Thus, this turbine passes the sensitivity test by a factor of 2.6.

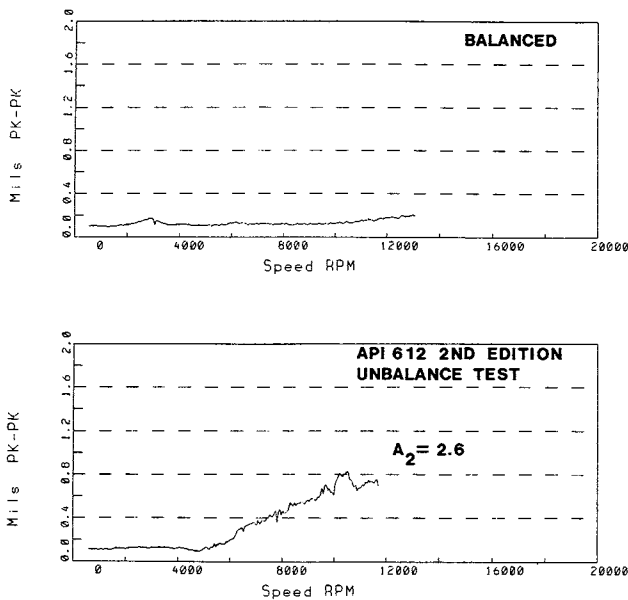

Figure 10. Test Stand Results, High Speed Turbine, WT = 620 lb,  $N = 10,920$  rpm.

While this example illustrates how the second edition works for both the vendor and user to produce an acceptable machine, it also amplifies a major problem with the specification. If the support stiffness is not included in the analysis or if an unreasonably high support stiffness is used, the predicted second critical would be outside the separation margin. Consequently, no unbalance test would be performed and the rotor vibration would only be seen in the balanced condition where detection of the second critical is essentially impossible.

A second example turbine is shown in Table 7 and Figure 11. From Table 7, the predicted second critical with flexible pedestals ( $KS = 5.0E6$  lb/in) is at 6800 rpm with an amplification factor of 11.1. Even with this high amplification factor, the rotor in

Table 7. Rotor Characteristics, High Amplification Turbine.

Rotor Weight (lbs)	11,445
Bearing Span (in)	118.5
Midshaft Diameter (in)	16.0
Journal Diameters (in)	7.0/6.0
MCOS (rpm)	6380
$N_1/A_1$ (predicted)	2450/10
$N_2/A_2$ (predicted)*	6800/11.1
$N_1/A_1$ (actual)**	2500/8.3
$N_2/A_2$ (actual)**	6400/10.7

\*With  $KS = 5.0E6$  lbs/in

\*\*Estimated from Figure 11

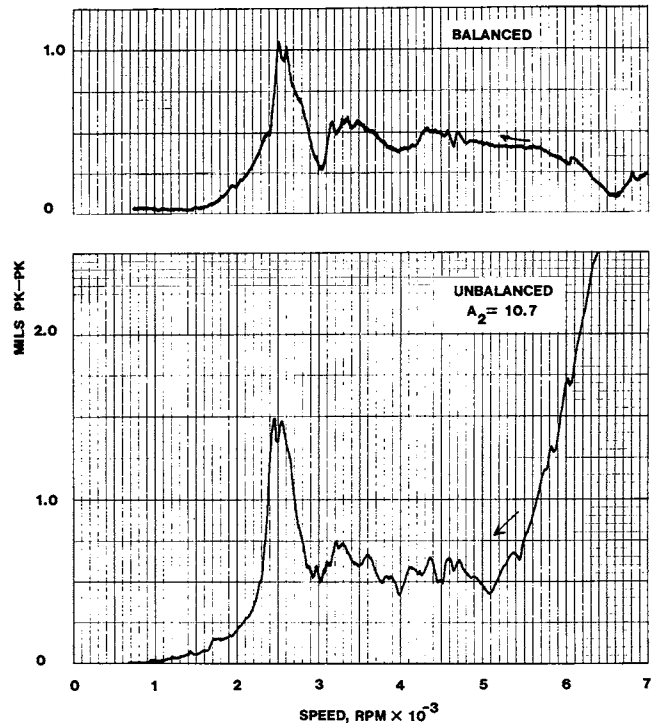

Figure 11. Test Stand Results, High Amplification Turbine, WT = 11,445 lb,  $N = 6380$  RPM.

the balanced condition (Figure 11) shows little evidence of the second critical. However, it is clearly evident in the unbalanced condition at around 6400 with an amplification factor of 10.7.

This turbine was designed in the seventies with a flexible bearing, rigid pedestal analysis that predicted the location of the second critical at 9500 rpm. Clearly, this turbine will only operate properly by keeping the rotor in balance. Applying the analytical methods available today, this turbine would not be built and indeed would never comply to either the second or the third edition of API 612.

Both example rotors in this section illustrate how machines may be designed to run below the second critical but end up operating on the second critical. Without including the flexibility of the pedestals in the analysis and applying the second edition, both of these rotors could be built today, tested without an unbalance test and shipped. One would run fine while the other may become a problem machine.

This problem is eliminated by the third edition as it requires an unbalance test for all rotors to verify the rotordynamic

analysis. With the third edition, reasonable support stiffness values must be used by the vendors if they expect their predictions to match the actual test stand criticals.

Incidentally, the second edition only requires the vendor to "...include his assumptions regarding...support stiffness..." [8]. However, the third edition contains a much stronger and more explicit statement. API 612 (third edition) [9] states that "support (base, frame, and bearing housing) stiffness, mass, and damping characteristics, including effects of rotational speed variation," shall be included. Furthermore, "the vendor shall state the assumed support system values."

*Applying API 612 Second and Third Editions*

Returning to the process gas turbine described in Table 1, the test stand results for the balanced rotor are illustrated in Figure 12. Since the second critical speed, predicted at 5500 rpm, is within the separation margin, an unbalance test is required by the second edition. The amount of weight required and the vibration limit is listed in Table 8.

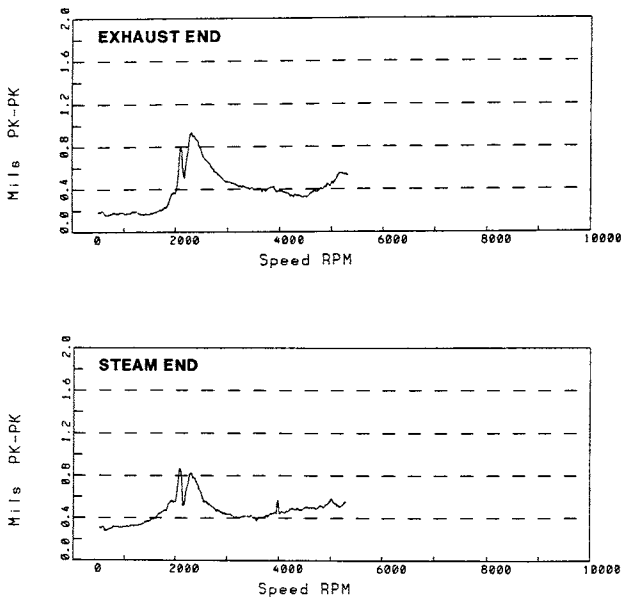

Figure 12. Test Stand Results, Process Gas Drive Turbine, Balanced.

Table 8. Summary of Unbalance Amounts, Vibration Limits, Predicted and Actual Maximum Vibration for the Process Gas Drive Turbine

Specification	Unbalance (oz-in)	Vibration Limit (mils)	Max Probe Vibration** (mils)	
			Predicted	Actual
API 612 2nd	91.2/91.2*	3.1	7.5 (Fig. 8)	6.0 (Fig. 13)
API 612 3rd	57.3/47.1*	15.0	4.8	3.5 (Fig. 15)

\*Exhaust/Steam End

\*\*at N = 5043 rpm

In Figure 13, with 1/4 of the second edition weights placed out-of-phase at the field balance planes inboard of each bearing, the resulting vibration at maximum continuous operating speed

(MCOS) is 1.5 mils. Four times this amount would result in approximately 6.0 mils, which is above the vibration limit by a factor of two. Results for 1/2 the second edition weights are shown in Figure 14.

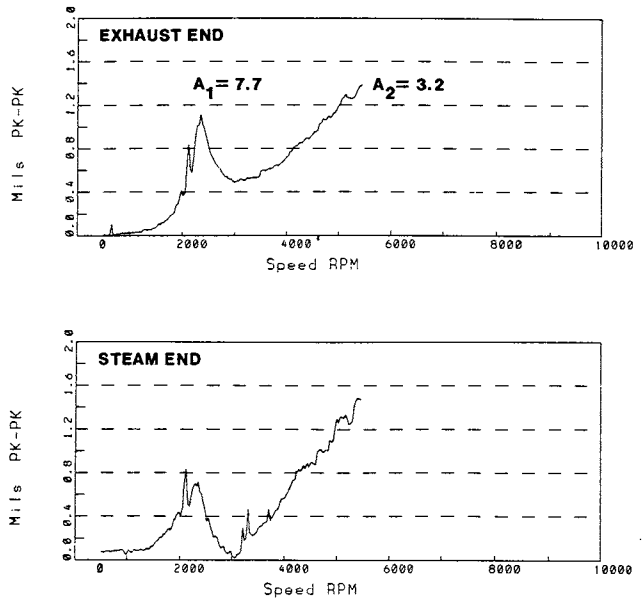

Figure 13. Test Stand Results, Process Gas Drive Turbine, 1/4 of API 612 2nd Edition Unbalance Weights.

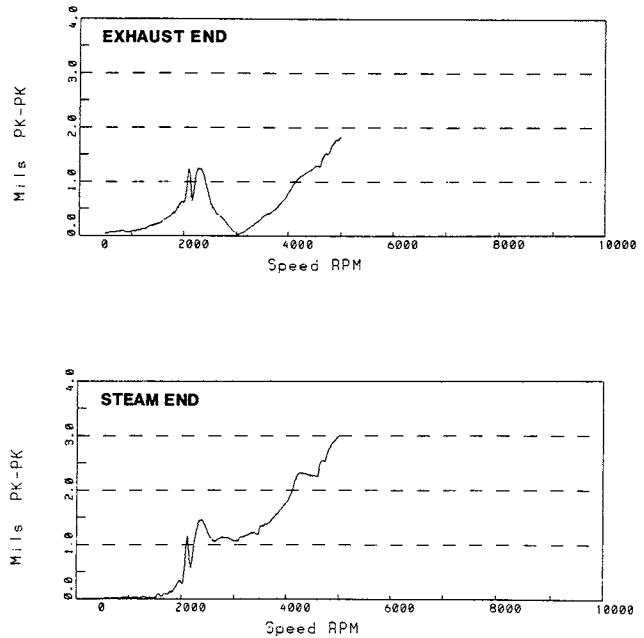

Figure 14. Test Stand Results, Process Gas Drive Turbine, 1/2 of API 612 2nd Edition Unbalance Weights.

While the process gas rotor and the rotor from Table 6 have identical amplification factors of 2.3, the light high speed turbine passed the second edition unbalance test by a factor of 2.6, but the heavy low speed process gas turbine failed by a factor of 2. This anomaly results from the equation used to calculate the amount of unbalance weight. From Table 4, the amount of unbalance is inversely proportional to the speed squared and directly

proportional to the rotor weight. Thus, for heavier, slower speed rotors, the unbalance amount required grows very quickly.

Conversely, from Table 5, the third edition equation is linear in weight and speed inverse. The amount of weight is listed in Table 8 that is required for the third edition, which is almost half of the second edition weight. The results for a third edition unbalance test are shown in Figure 15. The resulting vibration level at MCOS is 3.5 mils, which is well below the 15 mil vibration limit by a factor of 4.3. The vibration limit is 75 percent of the minimum seal clearance of 20 mils diametral (Table 5).

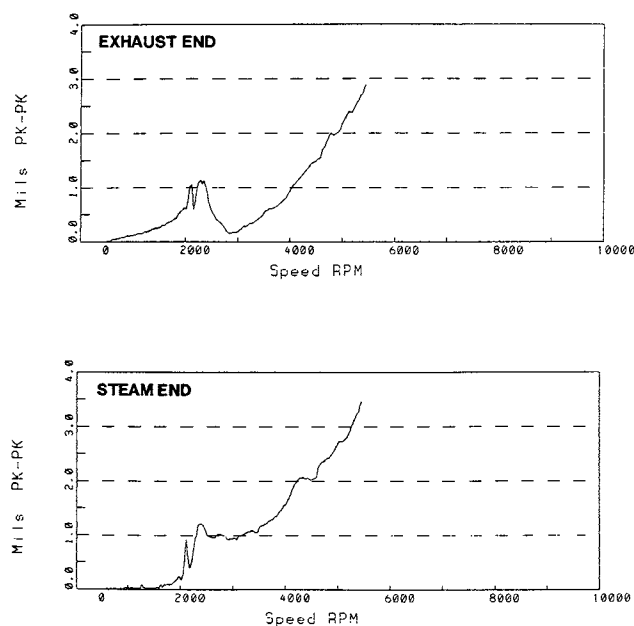

Figure 15. Test Stand Results, Process Gas Drive Turbine, API 612 3rd Edition Unbalance Weights.

A comparison of the predicted and the actual critical speed frequency and amplification factor is listed in Tables 1 and 8. Note that the analysis predicts 7.5 mils of vibration at MCOS for the full second edition weights (Figure 8) compared to 6.0 mils actual. The predicted frequency and amplification is 5500/2.3 while the estimated actual values are 5400/3.2.

## CONCLUSIONS

- It is not possible to accurately predict the location of the second critical speed without inclusion of support flexibility.
- Advances in rotordynamic analytical capabilities, especially in dynamic bearing analyses and in the support stiffness area, if used correctly can accurately predict both the location and amplification of rotor critical speeds.
- Since the second edition of API 612 does not always require an unbalance test, machines that are sold to operate above the second critical based on erroneous predictions may actually run on the second.
- Since the third edition of API 612 requires an unbalance test for all rotors, reasonable support stiffness values must be used in analyses so that predicted results will match test stand criticals. This also precludes any machine from leaving the test stand without knowledge of the locations of all critical speeds.
- While a light, high speed rotor with an amplification factor of 2.3 passed the second edition test by a factor of 2.6, the heavy, low speed process gas turbine with an identical amplification factor failed by a factor of 2.

- The process gas turbine failed the second edition unbalance test by a factor of 2 but passed the third edition test by a factor of 4.3.

- The acceptability of overdamped critical speeds in the operating speed range gives designers greater freedom in designing high performance turbomachinery. The process gas turbine passed the third edition unbalance test by a wide margin and should perform satisfactorily during field operation.

## REFERENCES

1. Tuttle, J. A., "Damping of Lateral Critical Speeds of Turbomachinery," ASME Paper 70-FE-14, (1970).
2. Lund, J. W., "Spring and Damping Coefficients for the Tilt-Pad Journal Bearing," ASLE Trans, 7, (4), 342-352 (1964).
3. Caruso, W. J., Gans, B. E., and Catlow, W. G., "Application of Recent Rotor Dynamics Developments to Mechanical Drive Turbines," *Proceedings of the Eleventh Turbomachinery Symposium*, Turbomachinery Laboratory, Department of Mechanical Engineering, Texas A&M University, College Station, Texas, pp. 1-17, (1982).
4. Nicholas, J. C., and Barrett, L. E., "The Effect of Bearing Support Flexibility on Critical Speed Prediction," ASLE Transactions, 29 (3), (July 1986).
5. Nicholas, J. C., Whalen, J. K., and Franklin, S. D., "Improving Critical Speed Calculations Using Flexible Bearing Support FRF Compliance Data," *Proceedings of the 15th Turbomachinery Symposium*, Turbomachinery Laboratory, Department of Mechanical Engineering, Texas A&M University, College Station, Texas, (November 1986).
6. Rouch, K. E., McMains, F. H., Stephenson, R. W., and Ermerick, M. F., "Modeling of Complex Rotor Systems by Combining Rotor and Substructure Models," ANSYS 1989 Conference Proceedings, Swanson Analysis Systems, Inc., Houston, Pennsylvania, 2, pp. 5.23-5.39 (May 1989).
7. American Petroleum Institute, "Special-Purpose Steam Turbines for Refinery Services," API Standard 612, First Edition, (November 1969).
8. American Petroleum Institute, "Special-Purpose Steam Turbines for Refinery Services," API Standard 612, Second Edition, (June 1979).
9. American Petroleum Institute, "Special-Purpose Steam Turbines for Refinery Services," API Standard 612, Third Edition, (November 1987).
10. Raynesford, J., "API 617 5th Edition/API 612 3rd Edition Rotor Dynamics," Transcript of Presentation at the Dresser-Rand Technology Seminar, (October 1988).

## ACKNOWLEDGMENT

All of the work herein was completed while the author was employed by Dresser-Rand, Steam Turbine, Motor and Generator Division, Wellsville, New York in collaboration with Richard J. Del Vecchio.

## NOMENCLATURE

- |               |   |
|---------------|---|
| $A_1, A_2, A$ | first, second critical speed amplification factor |
| KS            | support stiffness (lb/in)                         |
| $N = MCOS$    | maximum continuous speed (rpm)                    |
| $N'$          | maximum or minimum speed (rpm)                    |
| $N_1, N_2$    | first, second critical speed frequency (rpm)      |

8

UB unbalance (oz-in)  
V peak-peak vibration (mil)  
W journal static load (lb)  
WT total rotor weight (lb)



***ROTATING MACHINERY TECHNOLOGY***

**4181 BOLIVAR ROAD  
WELLSVILLE, NY 14895  
585-593-3700 (VOICE)  
585-593-2693 (FAX)**

**[www.rmt-inc.com](http://www.rmt-inc.com)  
[jcn@rmt-inc.com](mailto:jcn@rmt-inc.com)**